

# SHOW DAILY™

The official showdaily of IMTEX 2019

Day 2 • Friday, January 25, 2019

**"My clear choice."**



Titan Gilroy  
TITANS of CNC: Academy, USA

Meet our coolant experts at our booth A118 in Hall 3A and find out why Synergy 735 is the best metalworking fluid that Titan Gilroy has ever used.

[blaser.com/synergy735](http://blaser.com/synergy735)





**Win a trip to Switzerland.**



Enjoy a virtual visit to Switzerland at our **booth A118 in Hall 3A**, including a photo of yourself in front of a Swiss landscape as souvenir.

And with a bit of luck, you can win a trip to our head-quarters, where we will show you how our metalworking fluids can optimize productivity, economic efficiency and machining quality.

**blaser.com**

There will be no correspondence regarding the competition. The winners will be notified personally. Legal recourse is excluded.



# SHOW DAILY™

The official showdaily of IMTEX 2019

Day 2 • Friday, January 25, 2019

Accurate We build 'Q' for 'μ'

3D Coordinate Measuring Solutions



Visit us at

Hall No	Stall No
<b>3A</b>	<b>B-113</b>

www accuratesales.co.in

**ACCURATE**

Partnering Quality

**LEAPING AHEAD**

## Optimism Looms Large

IMTEX 2019 & Tooltech 2019 witnessed an unprecedented show of solidarity from the manufacturing community yesterday at its inauguration. The veterans proudly reflected on how far we, as a nation, have reached in the global manufacturing landscape and deliberated on filling the gaps to make wide strides to reach our goals. A fitting start to a very special golden jubilee of IMTEX.

The 19<sup>th</sup> edition of IMTEX and 21<sup>st</sup> edition of Tooltech, organized by Indian Machine Tool Manufacturers' Association (IMTMA), kickstarted on a high note yesterday at the Bangalore International Exhibition Centre (BIEC), Bangalore with visitors pouring in from a wide variety of sectors. The show holds a special significance this edition since IMTEX celebrates completing 50 years of being a world-class machine tools exhibition.



Industry veterans during the lamp lighting ceremony

**A perfect start**

IMTEX's golden jubilee edition had to have a perfect start to set the tone for the seven-day metal cutting fair that would display technological refinements in the field even from the farthest nooks of the world. Shri HD Kumaraswamy, Hon'ble Chief Minister of Karnataka, did the honors of inaugurating

the show in the presence of Shri RV Deshpande, Hon'ble Minister for Revenue, Government of Karnataka; Shri KJ George, Hon'ble Minister for Large & Medium Scale Industries, Government of Karnataka; Vikram Kirloskar, Vice President, Confederation of Indian Industry

(CII); and Ram Venkataramani, President, Automotive Component Manufacturers Association of India (ACMA).

**Fillip to the industry**

What started as a vision for an all machine tools exhibition has turned out to be a one of its kind

industrial exhibition in India. At this juncture, IMTEX 2019 is its most evolved and is the reflection of IMTMA's relentless enthusiasm to create a platform to nurture the Indian Machine Tools industry on par with international standards. It's only opportune that the show

To be continued on 6

"The REVO scanning capability allows us to catch from errors much more quickly, without a time penalty on our inspections. It has definitely made us more proactive in catching quality problems early in the game."

**Kawasaki's Maryville, MO Plant**  
(Motorcycle Manufacturer)



**RENISHAW** apply innovation™

IMTEX 2019 HALL - 3A STALL - 0103

VISIT US HALL - 6 STALL - 0102

**EMBARK YOUR SMART JOURNEY**



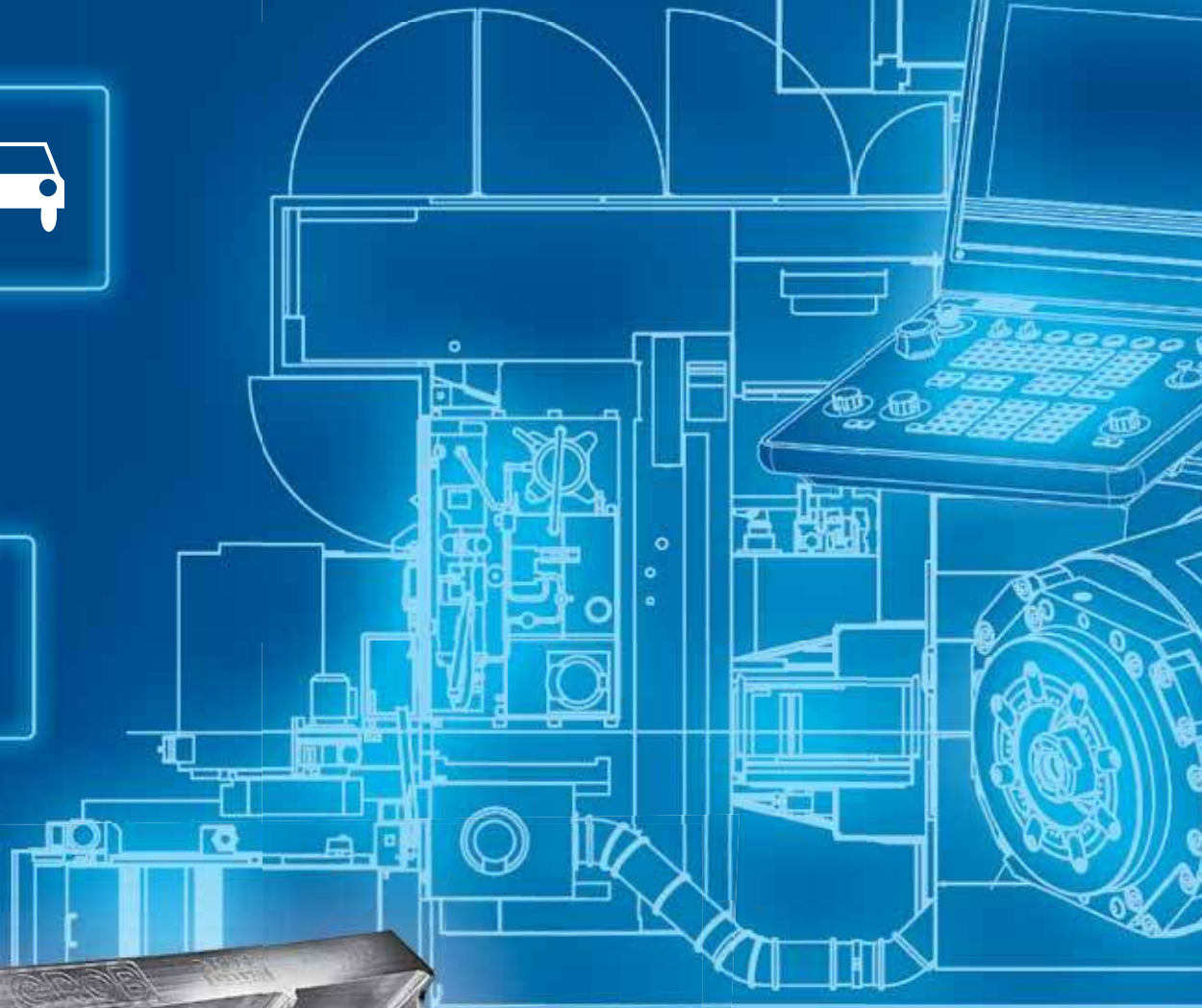

# G-SERIES

Precision at the highest level



GROB 5-axis universal machining centers stand out due to their absolute precision and reliability in the automotive, medical and mechanical engineering industries, in tool and mold making as well as in the aviation industry. The proven 5-axis simultaneous technology with horizontal spindle position enables you to machine parts of various sizes and materials in a flexible and failure-free way while offering maximum stability of the machine. Fast chip-to-chip times and the innovative further development of our spindle technology guarantee a high economic efficiency and productivity.

GROB MACHINE TOOLS INDIA PVT. LTD.  
HYDERABAD - 500 085, TELANGANA, INDIA HYDERABAD, INDIA  
SURVEY NO: 145, PLOT NO:32/B, 4TH FLOOR  
SARDAR PATEL NAGAR, HYDERNAGAR, KUKATPALLY  
PHONE / FAX: +91 (40) 4202-3336 | E-MAIL: INFO@IN.GROBGROUP.COM

[www.grobgroupp.com](http://www.grobgroupp.com)





# MOTUL

TECH

THE INDUSTRIAL  
LUBRICANTS DIVISION  
OF THE **MOTUL** GROUP

VISIT US  
**IMTEX**  
**2019**



METAL WORKING FLUIDS  
SPECIALITY LUBRICANTS  
MAINTENANCE LUBRICANTS  
HIGH PRESSURE DIE CASTING  
QUENCHING FLUIDS

**HALL 3-B**  
**STALL C-105**

**24<sup>TH</sup>-30<sup>TH</sup>**  
**JANUARY**  
**BIEC, BANGALORE**



[motul.com](http://motul.com)





Industry veterans at the ribbon cutting ceremony

Continued from 1

reaches its 50<sup>th</sup> year milestone when the Indian manufacturing industry is at a turning point.

“We are at the beginning of a promising year for the Indian economy, India GDP forecast for the current fiscal is 7.3 to 7.4 percent growth. I am sure that in the forthcoming financial year 2019-2020 we will see more vibrancy and robustness,” said P Ramadas, President, IMTMA.

“Manufacturing is seeing good growth in the country. The industry now needs to tap the various opportunities which are rising in defence, aerospace and other sunrise sectors. This will further

open doors for research and innovation. This will also supplement the industries export potential besides strengthening ‘Make In India’ and taking manufacturing sectors contribution to 35 percent of the country’s GDP,” he added.

Commending the industry on its growth, Shri RV Deshpande, said, “I have been very closely associated with IMTMA for the past few years. I applaud IMTMA’s efforts for taking the Indian Machine Tools industry to the global height. Almost up to 1995, we did not have any big automotive manufacturer in the country. Today, we have so many. This has been possible only because of the



Shri RV Deshpande, Hon'ble Minister for Revenue, Government of Karnataka planting saplings post inaugural ceremony at BIEC

growth of the Machine Tools industry. In Karnataka itself almost 120 companies are engaged in machine tools manufacturing.” Seconding him, Kirloskar noted, “The Automobile and the Auto Component industry both are globally expanding and the high-quality products are possible because of our Machine Tools industry’s development.” He cited three major areas – Energy Security, Environment and ‘Make in India’, where a long-term policy is needed and put forth his request to the union government to frame them.

Clearly proud to have IMTEX in the state of Karnataka, Chief Minister Shri HD Kumaraswamy said that he is glad to host all national and international guests in the state. “Today, the entire world knows Bangalore. This exhibition is of great significance to the Indian Machine Tools industry. I am glad to inform that Karnataka is the first state to declare the Aerospace

Policy. We are working on providing a dedicated space to set up this industry. We are also working on setting up our exhibition center close to the airport.”

### Celebrating 50 glorious years

2007 was the year when the journey of IMTEX took a more exciting turn when it settled in the BIEC, the world’s most professionally designed and created exhibition center. To cater to the growing needs of the industry, another Hall (Hall 5) has been added to the center, which was formally inaugurated at the hands of the dignitaries.

“I had the privilege of inaugurating the show and opening the BIEC when IMTEX entered Bengaluru 12 years ago. The exhibition has been a gateway for attracting investments in Karnataka since then,” said Shri HD Kumaraswamy recalling IMTEX’s first at the center. “It is IMTEX’s 50<sup>th</sup> year and 10<sup>th</sup> year in our own complex. I am glad to welcome 13 of our past Presidents with their families. They visualized much early to build what Indian Machine Tools industry is today. I am glad to say that we have been able to utilize the entire space that has been created within the complex. This is the biggest IMTEX so far,” said Jamshyd N Godrej, Chairman – Exhibitions, IMTMA.

6

Organizer  
**IMTMA**  
Indian Machine Tool  
Manufacturers' Association

CHENNAI  
**MACHINE  
TOOL EXPO** 2019

26 - 29 September 2019  
Chennai Trade Centre, Chennai

Delivered by the organizer of **IMTEX**

Biggest show in the region  
to connect with best manufacturing industries

For stall bookings contact  
IMTMA camp office at Hall No. 1

Special Pavilions

www.mtx.co.in



RECOGNITION & REWARDS

## Rajendra Jain honored with IMTMA-Doshi Award

Acknowledging his visionary pursuit of entrepreneurial excellence and unique leadership style, Rajendra Jain, Managing Director, ITL Industries has been honored with the IMTMA - Vinod Doshi Premier Outstanding Entrepreneur Award at IMTEX 2019. The award has been instituted in memory of Vinod Doshi, Chairman of Premier Ltd, an outstanding industrialist and one of the founding fathers of IMTMA. Described as a diligent, determined, creative and compassionate mechanical engineer by his close associates, Jain’s entrepreneurial journey has been of challenges and winning over them. With his spirit to consistently innovate, he introduced the first indigenously designed Double Column Type Band Saw Machine in 1988. It was Jain’s inherent leadership qualities that resulted in turning a partnership firm, ITL Industries, to a Public Limited Company within no time.

Source: Magic Wand Media



# NEW MINT SERIES URXH ROTARY TABLE



**Made In India. For The World.**

**Your Partner In Productivity**

**Witness Our Wide Range of 4th & 5th Axis Rotary Tables**



[www.ucamind.com](http://www.ucamind.com)

**IMTEX 2019**  
Jan., 24-30, 2019



FROM FAR & WIDE

# In the Right Direction

With IMTEX celebrating 50 years, Dr Wilfried Schäfer, Executive Director, VDW, says it has become meaningful over the years.

For German manufacturers, trade fairs like IMTEX take priority considering that they have a fairly large market base here through numerous representatives. Dr Wilfried Schäfer, Executive Director, German Machine Tool Builders' Association (VDW), affirms that trade fairs like IMTEX become a homing ground for business between machine tool suppliers and customers.

## India-Germany make great partners

According to Schäfer, India is one of the world's largest machine tool markets. He shares the import-export data between India and Germany, "In 2017, machines worth almost €2 billion were consumed. The country imported 60 percent of this. With a share of



“Over the past 50 years, the organizers have been outstandingly successful in fulfilling this role. For 18 years, VDW and the Indo-German Chamber of Commerce have been organizing a joint German stand, which continues to be well received.”

**Dr WILFRIED SCHÄFER**  
Executive Director, VDW

16 percent, Germany ranks third among the most important suppliers after Japan and China. The same year, German deliveries increased by more than a fifth. In the first three quarters of 2018 they lost slightly, 3 percent to just under €150 million. It was mainly parts and accessories, gear cutting machines and machining centers that India's industry had ordered.”

**German Machine Tool Builders' Association (VDW)**  
www.vdw.de  
Hall 3B, Booth C104 / 3C, E108



**Lakshmi Machine Works Ltd**  
www.lmwncnc.com  
Hall 5, Booth B106

VERTICAL MACHINING CENTERS

# LMW launches JU 60 VMC

Lakshmi Machine Works Ltd (LMW) yesterday at IMTEX 2019 launched a 5-axis simultaneous VMC. The JU 60 provides high speed and accuracy in complex part machining with a built-in spindle of 15,000 rpm. It has ideal axes layout with 2 spindle axes and 3 table axes. The machine has a symmetrical structure for thermal stability and comes with an automatic tool changer with 40 tools. For higher accuracy and high rapid traverse rate (X,Y, & Z axes 48 m/min), it has BBT40 spindle taper. Better tool clamping and higher material removal is achieved due to BBT spindle. It has a larger clamping area (dia. 500 mm) and Siemens 840 D Control system.

# PMT Machines Limited

• Pune • Halol

CUSTOMISED SOLUTIONS

CELEBRATING 57 YEARS

CNC Turning	Automats	CNC Internal Grinding	CNC Cylindrical Grinding	Surface Grinding
CNC HEAVY DUTY LATHE	A15/25	BIG BORE GRINDER	AUTO LOADING	HYDRAULIC / PLC
SC-12 Ø400 CHUCK	TD36	ID / OD GRINDER	LONG SHAFT GRINDER	CREEP FEED GRINDER

Built To Last



**PMT MACHINES LIMITED**  
Head Office & Works : P. O. Box No.1102, Behind PCMC Building, Mumbai - Pune Road, Pimpri, Pune - 411 018. (India)  
Tel. No. : +91-20-27426219 to 23 • Fax. : +91-20-27426231/35 • E-mail: rd@pmtmachines.com, marketing@pmtmachines.com • website: www.pmtmachines.com  
Halol Works : 178, Kadachala, Halol - 389350, Gujarat (India)  
Tel. : +91 02676 246786/87 • Fax. : +91 02676 246788 • E-mail : cb@pmtmachines.com, mkt.brd@pmtmachines.com

Pune : 9730576789; Mumbai : 9821713400; Delhi : 9810401815; Bangalore : 9845026905; Chennai : 9840896822; Coimbatore : 9840366822; Jamshedpur : 9934119234; Vadodara : 9862503927



Visit us at  
Hall 5 • Stall A103

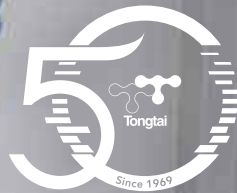

**東台精機**

複合式加工中心機  
Multi-tasking Machining Center

CT-350



**榮田精機**

CNC立式車銑中心  
CNC Vertical Turning Center

VL-160CM

# TT GROUP

東台集團

Total Solutions Provider

Booth No. **Hall5 A120**



**APEC 亞太菁英**

航太加工解決方案  
Aerospace Machining Solutions

G3020



**quicktech 譚泰精機**

14軸連動數值控制CNC車銑複合式車床  
Advanced Multi-tasking Lathe

I-42U







Source: Blaser Swisslube

Technology Centre of Blaser Swisslube

**Blaser Swisslube**  
[www.blaser.com](http://www.blaser.com)  
Hall 3A, Booth A118



Source: Blaser Swisslube

“Liquid Tool is built on competence and expertise at Blaser Swisslube including its people, technology driven formulations and customized services. It is possible to gain much larger benefits by having a strong trust in this approach.”

**PUNIT GUPTA**  
Managing Director  
Blaser Swisslube India

## METALWORKING FLUIDS

# Doing Cool Stuff



**Punit Gupta, Managing Director, Blaser Swisslube India, believes in having a sustainable long-term way to generate added values for its customers and create long-term partnerships with them, its employees and channel partners.**

**P**unit Gupta, Managing Director, Blaser Swisslube India, says with certainty that the competence of suppliers and customers must work together in a collaborative way to reach higher standards of working. “Customers need competent partners who work with their strengths, bring the technology expertise and contribute to increased competitiveness. As a globally active and focused company, we have geared up to collaborate with our customers and bring in new tech-

nologies and generate added value for our customers through Liquid Tool,” he says. Every element in manufacturing must generate returns on investment rather than expenditure. People would then definitely find it interesting to change their approach in manufacturing. With years of focused engagement with the metalworking operations, Blaser Swisslube developed the concept of Liquid Tool - a new dimension in productivity & profitability. An area of Metalworking Fluid, which was

often neglected and considered as a necessary evil, has been completely transformed with Liquid Tool concept. It allows manufacturers to exploit the potential of machines and tools to a larger dimension. Liquid Tool is built on competence and expertise at Blaser Swisslube including its people, technology driven formulations and customized services. It is possible to gain much larger benefits by having a strong trust in this approach. Tests at customers’ end have shown that there are possibilities of increasing the tool life by 20-40 percent and to increase the productivity to the tune of 8-15 percent by working together.

### Meeting requirements

Blaser Swisslube India is showcasing Synergy 735 at IMTEX 2019. It is a crystal-clear, innovative, water-miscible and oil-free metalworking fluid that ensures spotless surfaces that are easy to clean thanks to its

neutral pH and outstanding rinsing behavior. Synergy 735 has a neutral odor, excellent skin compatibility and offers a clear view of the machining process. It performs in a variety of materials such as titanium and aluminum alloys as well as steel and stainless steel, copper alloys and composites. Blaser Swisslube has created optimum conditions for simulating and testing the latest machining technologies at its in-house Technology Center in Switzerland. “Our Technology Center is unique in the industry and it’s where we develop and test the latest metalworking fluids before they come to market,” Gupta shares summing up.

## ATOS 5/5X Automated Large Volume 3D Scanning



APM Technologies

Fully Automated 3D Scanning & Advanced Inspection Solution

### ATOS 5-Innovation Realised

- High measuring speed 0.2 sec per scan
- Blue light equalizer
- Laser light compressor
- Fibre optic connectivity
- Robot precision
- Triple scan principle
- Optical & Tactile measurement
- Assured measuring quality



New Delhi | Pune | Bangalore | Chennai

Email : [sales@apmtechindia.com](mailto:sales@apmtechindia.com)

Website: [www.apmtech.in](http://www.apmtech.in)

Phone : 011-41631416, 41631454, 41600020

Visit us at:  
Hall-2B, Stall no-F105

# TURNKEY SOLUTIONS FOR AUTOMATED TURNING SOLUTIONS

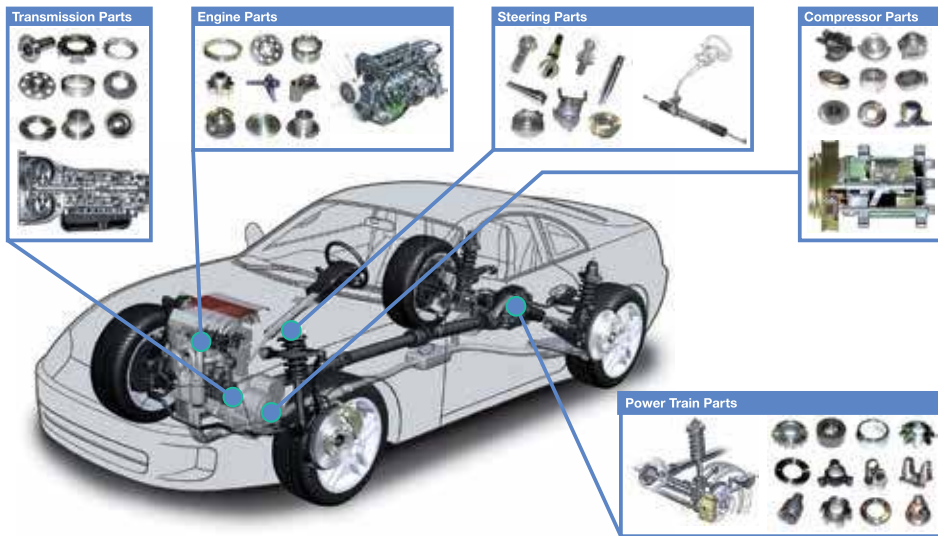

To meet the expanding global supply market requirements, Muratec has been a global leader in supply of Turning machines with advanced automation solutions. We are fully prepared to provide the most appropriate level of automation solution to meet the growing demand in India for medium to high volume global supply market combined with high-precision Standards. It also caters to the rapidly increasing volume requirements of the domestic Indian automobile industry.

Our MW/MS Series Twin and Single spindle automated turning machines and MD series turning centers have more than 10,000 installations worldwide. We are proud to say that, "MURATEC MOVES YOUR CAR".

MURATEC machines are available in a wide range of chuck sizes: capacities ranging from 6" to 15" chuck size.

These advanced, precision turning machines come with highly reliable, integrated, intelligent CNC 3 axis servo controlled gantry loader for smart, fully automated, flexible workpiece load/unload operations.

**Total Solution is Basic Turning Machine**  
**PLUS Peripherals & Options to Achieve Full Automation for Unmanned Operations on 24 x 7 Basis**  
**Standardized & Customized units to JUST-FIT Your Productivity Needs**



Muratec Flexible Automated 7 Spindle Line: MW200 + MW200 + MS100 + MD180

You think all this is beyond your financial strength?

Contact us for a detailed Economic Analysis of your Production Needs.

Small Enterprises to large multinational have reaped the benefits of MURATEC's TOTAL SOLUTIONS even in India for past 2 decades.

## Meiban - Muratec Turnkey Centre in Bangalore, India

Muratec has established itself as a strong player in offering total turnkey solutions which include right from process selection to time study preparation to selection of tooling and chucks to prove out at Technology Centre and at customers place.

- Turning solutions
- Application support
- Technical proposals
- Service support
- Customer training
- INR Sales with quick delivery



Visit us at  
Hall 5: Stall: C101







**APM Technologies**  
www.whitelightscanning.com  
Hall 2B, Booth F105

Developed for industrial use, ATOS 5 delivers high-precision data even under non-standard conditions.

**METROLOGY**

# 3D Scanner ATOS 5

ATOS 5 delivers high-precision data for a diverse range of manual and automated applications.

**A**TOS 3D scanners are replacing tactile measuring systems and gauges in many areas of industry. In a short time, they capture more detailed and easily interpretable quality information about an object. The sensors provide full-field deviations between the actual 3D coordinates and the nominal CAD data.

**For diverse applications**

ATOS 5 sensor provides full-field 3D coordinates for each individual measurement. Within a few seconds, up to 12 million independent measuring points are captured per scan. With its powerful light source, ATOS 5 delivers high-precision data for a diverse range of manual and automated applications: from tools and moulds to plastic and metal parts. The GOM data quality is particularly evident in the detail sharpness of the 3D

models, for instance in precise display of smallest details like rib structures, narrow radii or hemmed edges. The Blue Light Equalizer of ATOS 5 is so powerful that even unconventional surfaces can be scanned in short measuring times, making the precise coverage of complex geometries possible. In addition, the 3D Scanner is equipped with a Blue Light Equalizer, which increases the brightness of the light source by a factor of 1.5 and transmits uniform, non-coherent, speckle-free light to the projection unit. Developed for industrial use, ATOS 5 delivers high-precision data in a short measuring time even under non-standard conditions. The full-field 3D measuring data allows comprehensive process and quality control, visualizing hidden errors and thus speeding up production processes.

**ELECTRIC & ELECTRONIC EQUIPMENT**

# Reigning Globally

Mitsubishi Electric India Pvt Ltd considers IMTEX & Tooltech as an ideal platform for showcasing its products and is, therefore, a regular participant of the show. The company is displaying latest from its extensive product stable including controllers, motors and amplifiers.

**M**itsubishi Electric has been participating in IMTEX since the year 2010 and considers it as one of the major promotional events for CNC. “The exhibition is an ideal platform for CNC manufacturers such as Mitsubishi Electric to showcase advanced technological products and interact with various machine tool builders as well as end-users,” says Shuhei Matsui, General Manager – CNC Systems, Mitsubishi Electric India Pvt Ltd. “We would like to encourage our MTB partners to display ma-

chines with Mitsubishi CNC to showcase our latest technologies such SSS-4G, Interactive Cycles, Touch Screens and SD cards etc.,” he adds.

**On the showcase**

Mitsubishi Electric is displaying its latest product line-up consisting M80, M800, C80 and E80 along with Motors and Amplifiers. M80 controllers are capable of handling up to 12 axes targeted for VMC and Die-Mould applications. M800 is high-end controller capable of handling up to 32 axes



Source: Mitsubishi Electric India Pvt Ltd

“Technologies such as IoT, Edge Computing, Cloud, AI, etc. help integrate the whole factory from raw material to finished goods, procurement to sales, vendor to customers.”

**SHUHEI MATSUI**  
General Manager –  
CNC Systems  
Mitsubishi Electric India Pvt Ltd

on IoT and 3D printing. “Some of our partners are displaying machines with Mitsubishi CNC in this section. We expect the new technologies should be available to customers to enhance their manufacturing capability,” he adds.

**Smart moves**

Matsui thinks that manufacturing units should make use of latest technologies such as IoT, Edge Computing, Cloud, AI, etc., thus enabling them to grow. “These technologies help integrate the whole factory from raw material to finished goods, procurement to sales, vendor to customers, etc. Automation, Digitization and Visualization are the key elements of Smart Manufacturing. The e-Factory from Mitsubishi Electric is a one-stop solution for all the smart manufacturing needs. Mitsubishi Electric pioneered the e-Factory concept in Japan in 2003, which is currently deployed in more than 130 companies worldwide,” adds Matsui. Mitsubishi Electric entered the CNC business in India in 2010, and since then has grown five times. It has partnered with most Indian machine tool builders. Initially, it entered the die-mould market with its high-end CNC M70/M700 and captured 80 percent market share. It has sold the CNC in different segments such as grinding, honing, gear hobbing, engraving, gantry etc.



**Mitsubishi Electric India Pvt Ltd**  
www.MitsubishiElectric.in  
Hall 1A, Booth B107

Source: Mitsubishi Electric India Pvt Ltd



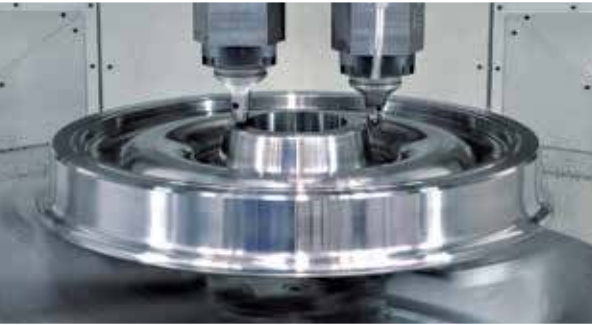

**FFG – YOUR GLOBAL  
MANUFACTURING PARTNER**



**VISIT US  
JANUARY 24 – 30, 2019  
HALL 4 / STALL B112**



**VDF BOEHRINGER**

**HESSAPP**



**meccanodora**



**MORARA**



**TACCHELLA**

**WITZIG & FRANK**

**DMC**



**LEADWELL**



**FFG Europe & Americas | MAG India Industrial Automation Systems Pvt. Ltd.  
sales-india@mag-ias.com | phone number: +91 80 406 77 000**





**Chiron India Machine Tools Pvt Ltd**  
www.chiron-group.com  
Hall 4, Booth A108

“We have been able to provide our customers the best solutions and support to their satisfaction.”

**RAJESH T GHASHI**  
Managing Director  
Chiron India Machine Tools Pvt Ltd

**VERTICAL MACHINING CENTRES**

## Partners in Growth

Rajesh T Ghashi, Managing Director, Chiron India Machine Tools Pvt Ltd, believes that the key to happy customers is being a partner to them along every step of their journey.

Chiron India Machine Tools Pvt Ltd knows that IMTEX is an opportunity that comes its way every two years. The company plans to maximize its presence and demonstrate a live show displaying solutions for manufacturing complex parts. In this backdrop Rajesh T Ghashi, Managing Director, Chiron India Machine Tools, says it aims to depict its capability as the right manufacturing solutions partner to the industry. “As Chiron Group, we have the complete ability to provide complete manufacturing solution inclusive of automation and Industry 4.0 solutions,” he adds.

At IMTEX 2019, the company is displaying its high-precision high-productive Twin Spindle Vertical Machining Centre with workpiece changer. The DZ 12 W model has

a spindle distance of 250 mm, 15,000 rpm spindle, 45 Nm Torque, rapids of 75m/min in all axis with acceleration of 1 g in X and 1.5 g in Y and Z axis. The machine is equipped with 2x32 HSK A50 Automatic Tool changer and Fanuc 31iB5 CNC system.

**Current adoption**

Ghashi seems pleased that the organizers have made room for two separate pavilions this time round – One for Additive Manufacturing and the other for Industry 4.0. “We would like to see the number of players who will bring with them capabilities and showcase their contributions. It would be really interesting for industrial visitors / academicians to see the latest trends which they can think of adapting in their present manufacturing environment,” he adds.



**Mahr Metrology India Pvt Ltd**  
www.mahr.in  
Hall 2B, Booth F101

**LAUNCH**

## Contour Measurement in a New Dimension

MarSurf CD Series promises speed, productivity and precision.

At IMTEX 2019, Mahr is unveiling its new product series for tactile contour measurement that promises speed, productivity and precision. The company believes that shorter measurement time increases performance. Marsurf devices are therefore optimized to accelerate measurement process and simplify handling. The new products have innovative clamping system, higher axis speeds, and intelligent probe arm system to make Mahr’s customers quality assurance more reliable and automatic.

**IMTMA Technology Centre**  
Indian Machine Tool Manufacturers' Association  
www.imtmatraining.in

**Live Demo @ IMTEX 2019**

**“Implementing Industry 4.0 in Manufacturing” @ IMTMA Technology Centre**

**Schedule:**  
Each day from 25.01.2019 to 29.01.2019  
Session 1 : @ 11:00 am  
Session 2 : @ 03:00 pm

**Live dome of data capturing and analysis covering :**

- Production Analytics, Quality Analytics & Visual displays
- Traceability during the entire manufacturing cycle right from raw material / stores to finished goods / despatch using barcode scanners and mobile apps



**MODERN MANUFACTURING INDIA**  
www.mimindia.co.in

The Official Magazine of  
Indian Machine Tool  
Manufacturers' Association  
In Association with  
Modern Trade Shows

**Reach Buyers Not Bots**

Source: Magic Wand Media

Source: Mahr Metrology India Pvt Ltd



## Designed for the machining of complex aerospace components



### Mazak « FOR AEROSPACE INDUSTRY

Machine tool manufacturers are required to supply high-performance, high-productivity and high-accuracy 5-axis machines and multi-tasking machines and propose new techniques to process difficult-to-cut materials and integrated components.

Mazak's extensive product range includes various machines suitable for the aircraft industry, and today many Mazak machine tools are playing active roles in aerospace manufacturers around the world.



Multi-tasking machine

#### INTEGREX i-200

**Multi-tasking machine, features a large machining area and high accuracy performance**

- Long strokes for large workpiece capacity.
- Unsurpassed versatility thanks to B-Axis and C-Axis contouring.



Multiple-Surface / Simultaneous 5-Axis Machining center

#### VARIAXIS i-500

**High-speed multi-surface machining of small and mid-sized workpieces by tilting rotary table**

- 5-axis simultaneous machining centers designed for exceptional versatility.
- Excellent machine design for both higher productivity and ease of operation







(L-R) Sanjay Sangam, National Sales Head, Renishaw India; Chief Guest TR Parasuraman, Deputy Managing Director, Toyota Industries Engine India; Paul Gallagher, Vice President and Director, Renishaw APAC; and Paul Weaver, Vice President, Renishaw India present during the Smart Factory Launch

NEWS

## Renishaw displays intelligent solutions

Global engineering company, Renishaw, is here at IMTEX 2019 to showcase a complete automation cell, demonstrating to manufacturers how intelligent process control (IPC) is key to the operation of a successful smart factory. Additionally, it is also launching several new products to address the industry's need for automated process control. Renishaw's technology provides manufacturers with measurement data to enable intelligent decision making, a crucial part of Industry 4.0. By providing equipment for machine calibration, on machine measurement, off-machine gauging and verification, Renishaw enables manufacturers to improve their processes and quality, while reducing CNC machine stoppages.

### Innovations galore

At the show, the company is demonstrating IPC for larger parts through Equator 500. "Intelligent process control is a crucial part of the Industry 4.0 journey for companies in the metal cutting industry. Renishaw is a leader in automation for machine tool and will demonstrate to visitors a complete automation cell, so they can experience IPC for themselves," said Paul Weaver, Vice President, Sales and Marketing, Renishaw in India. Renishaw also has a separate AM stand, where it is exhibiting the four-laser RenAM 500Q that speeds up the process by up to

four times in the most commonly used platform size, without any compromise on quality. It is also demonstrating its software for metal AM including QuantAM build preparation software, remote process monitoring application, InfiniAM Central, and the InfiniAM Spectral application for the live feedback on energy input and emissions. Among many more, the company is also showcasing a new version of SupaTouch, an intelligent optimization routine as part of its Inspection Plus macro software for machine probing cycles, which leads to a cycle time reduction for CNC machine tools of up to 60 percent. Its new CARTO 3.0 software supports the XR20-W rotary axis calibrator to quickly capture and analyze data from rotary axes. This provides an easy-to-use and intuitive software solution for all Renishaw laser calibration products, reducing the calibration time of a 5-axis machine tool to several hours. Visitors can learn more about Renishaw's popular smartphone apps including GoProbe, which generates code for machine tool probing and the Trigger LogicTM app, which provides users with a simple way to customize their Renishaw probe settings.

**Renishaw Metrology Systems Ltd**  
www.renishaw.com  
Hall 3A, Booth B103  
Hall 6, Booth D102

### MACHINING SOLUTIONS

## DMU 50 3<sup>rd</sup> Generation

With DMU 50 3<sup>rd</sup> Generation, DMG MORI has managed to harmonize the modern appearance of the design with user-friendly operation. The large, smooth opening door to the work area, for example, with a width of 876 mm ensures unrestricted access from the front, even in combination with automation solutions. The table also has an ergonomic loading height of 800 mm. The optimum

accessibility of the DMU 50 3<sup>rd</sup> Generation even encompasses maintenance components such as the control cabinet, fluid box, oil mist separator, heat exchanger and cooling unit. Travel paths of 650x520x475 mm and workpiece weights of up to 300kg mean the new DMU 50 3<sup>rd</sup> Generation covers a wide range of components. Its new NC swivel-rotary table with an enlarged swivel range of -35°/+110° boosts this versatility. A rapid traverse of 42 m/min and 30 rpm in the swivel-rotary axis ensure the dynamics for 5-sided to 5-axis simultaneous machining. In addition to the 15,000 rpm speedMASTER® motor spindle, the user can also choose between motor spindles with up to a 20,000 rpm. Also available as an option is an expanded tool magazine with up to 120 pockets. There are 30 tool pockets in the standard version.

**DMG MORI India Pvt Ltd**  
www.dmgmori.com  
Hall 4, Booth B101

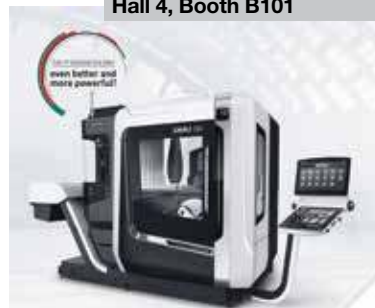

Source: DMG MORI India Pvt Ltd



## TUMAKURU MACHINE TOOL PARK (TMTP)



**(A Special Purpose Vehicle of GOI & GOK)**  
3<sup>rd</sup> Phase, Vasanthanarasapura,  
Tumakuru District, Karnataka Exclusively For  
Manufacturers Of Machine Tools And Their Ancillary Industrial Units.

Invitation for Allotment of Industrial Plots at  
**TUMAKURU MACHINE TOOL PARK**

**HIGHLIGHTS OF THE PROJECT:-**

- TMTP is being developed in about 530 Acres, as a self contained gated community with world class infrastructure.
- The Industrial Park will have state of the art infrastructure with eco-friendly layout exclusively for manufacture of Machine Tools.
- Power Supply – Distribution network with UG cables and supplementary solar power (Uninterrupted power supply.)
- Dual water supply system - potable & non-potable, underground Sewerage System.
- Power, water and sanitation points at each plot. Ready for "plug & play".

**CONNECTIVITY**

- 20 Km from Tumakuru town and 90 Kms from Bengaluru, along the NH-4 leading to Mumbai.
- Nearest Airport: Kempegowda International Airport (105 Kms), accessible bypassing Bengaluru City.

**COMMON FACILITIES:-**

- Common Engineering Facility Centre (CEFC); Test and Certification Centre (T&CC); Research & Development Centre (R&D); Incubation Centre for Startups.
- Investment promotion subsidy; Exemption for business development; Incentive and Concessions to MSME's as per Karnataka Industrial Policy 2014-19.

**Sri. Gaurav Gupta, IAS**  
Principal Secretary to Govt.,  
C&I Department, GoK

**Dr. N. Shivashankara, IAS**  
CEO&EM, KIADB

Please visit our website for apply: <https://kum.karnataka.gov.in> or  
[https:// ebizkarnataka.gov.in](https://ebizkarnataka.gov.in)



THE FUTURE STARTS HERE

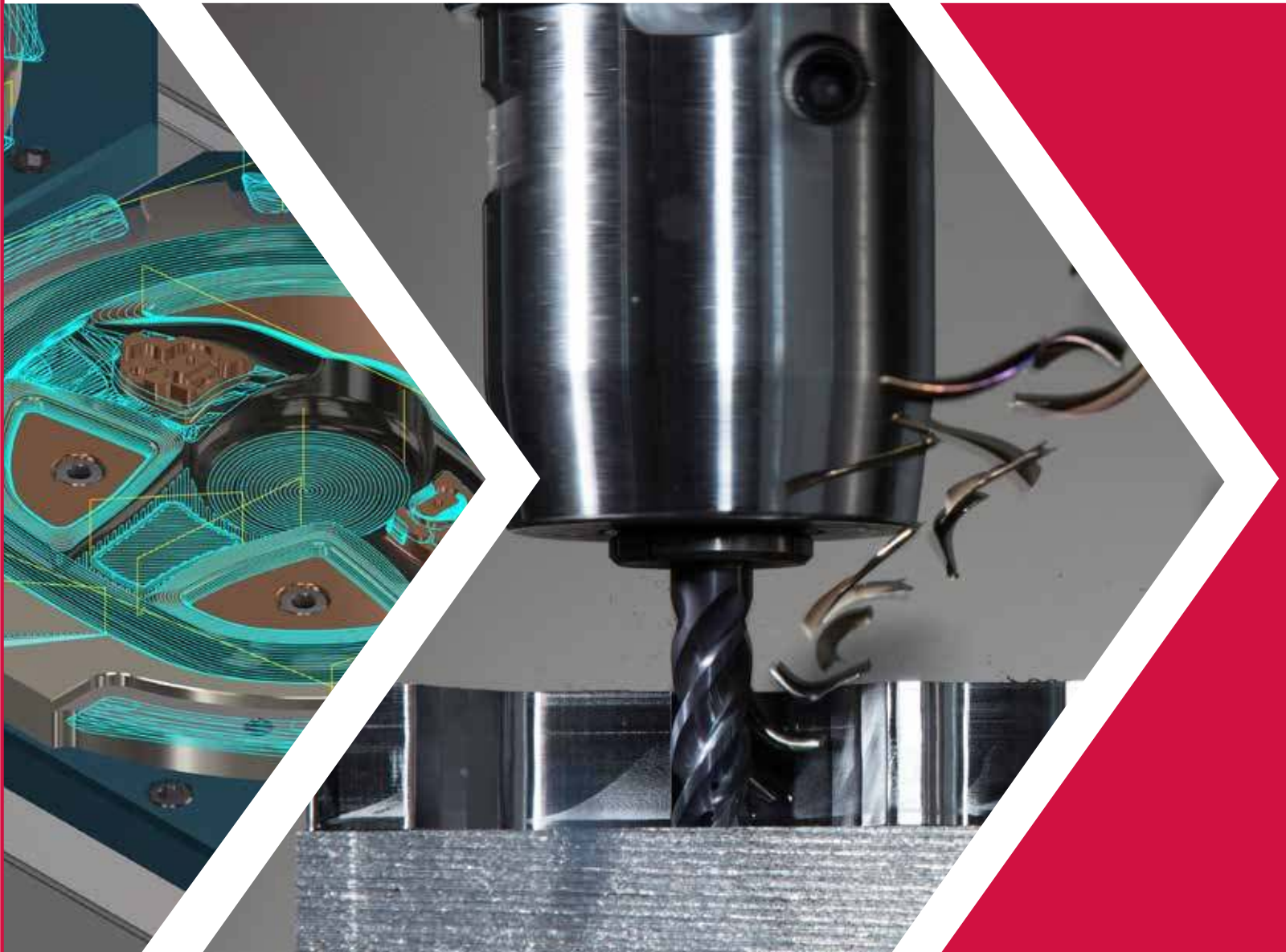

## *Mastercam* 2019

To see how Mastercam 2019 helps streamline your entire process, from job setup to job completion, visit [Mastercam.com/2019](http://Mastercam.com/2019).



Preparation/  
Setup



Tool Support



CNC  
Programming



Validation



Job Management  
& Documentation

VISIT US AT BOOTH C101 IN HALL 1B, TO AVAIL SPECIAL OFFERS!





## SmartFix4.0

IoT enabled Industry 4.0 fixtures for High Performance Machining.  
 Cloud based application that monitors readings from sensors on fixtures.  
 Fixture level analytics to help isolate and troubleshoot faster.  
 Graphical data with robust analysis.

**RV Forms & Gears LLP**  
www.formsandgears.com  
Hall 6, Booth B107

Source: RV Forms & Gears LLP

**WORKHOLDING SOLUTIONS**

Factory of the  
**FUTURE**  
An Epiphany in Industry 4.0

## Smart Fixtures - The Next Revolution

Smartfix 4.0 can be installed on even existing fixtures currently running in plants.

Forms and Gear's Fixture building expertise, in partnership with ASM Technologies' IT, Data Analytics and Artificial Intelligence strengths, has resulted in the development of Smartfix 4.0 - a revolution in Fixture Building and Workholding.

Smartfix 4.0 is a Fixture / Precision Workholding Device with the ability to collect, transmit and analyze data in a useful format to the end user. As the fixture is in continuous contact with the component, it is the ideal device to collect and analyze data at a component level. Sensors to monitor vibration, pressure, and component sensing are mounted on the fixture. And sensors to monitor oil levels and temperature are mounted on the powerpack.

Data collected from these sensors are transmitted wirelessly to the cloud where the data is then processed using Data Analytics and Artificial Intelligence. The analyzed data is then presented to the end user through a custom-built mobile application platform.



**CNC Software, Inc.**  
www.mastercam.com  
Hall 1B, Booth C101

Source: CNC Software, Inc.

**INDUSTRY-ACADEMIA**

Visit us at  
Hall 3C

## IMTEX 2019 hails 50 Academic Institutes

In a bid to forge the highly crucial Industry-Academia bond, IMTMA has called upon academic institutes to display their innovations and closely gauge industry requirements. Seventeen institutions from Bangalore and 33 from outside including two IITs are participating in the i2 Academia Pavilion at IMTEX 2019 & Tooltech 2019. Although most of them are displaying their R&D projects through posters, a few are showing live demonstrations of their innovations.

The students from NMAM Institute of Technology (NITTE) are showcasing a Noble Drilling Technique. With a normal drill bit it is not possible to drill beyond a certain depth. To resolve it, they have developed a technology by which they charge a mist coolant to facilitate the process. They are in talks with SKF Industries to introduce this technique.

Nagendra Jayaram, Senior Assistant Professor, Mechanical Engineering Department, New Horizon College of Engineering, shared, "We are showcasing our Centre of Excellence (CoE) for the Additive Manufacturing technology, some other techniques of manufacturing and innovative surface enhancement technologies. In our CoE, we can customize the material that is to be printed. We are primarily focusing on plastic waste materials, which are carelessly disposed. With our FDM printer we make technical parts from the waste thermoplastics."

Sathithya Yogi from Chennai Institute of Technology said, "We have developed an automated trolley that can move and turn in any direction within a very narrow place. This is a specialized application of Human Machine Interface (HMI). Although such products are already available in the market, this development drastically reduces their cost."

Nehal Ahmad from HKBK College of Engineering said, "We are displaying design and fabrication of power generating systems from various moving devices. For example, power can be generated even from a treadmill. We are trying to show all such new concepts at the show."



Source: Magic Wand Media

**MANUFACTURING SOFTWARE**

## 3-Axis and 4-Axis Mill Post Processor

This new post processor has been developed with the technical aid of Siemens CNC engineers.

CNC Software, Inc., producers of Mastercam CAD/CAM software, announces a 3-axis and 4-axis milling post processor that will unleash the highest productivity on SINUMERIK-controlled machine tools. This new post processor was developed utilizing the technical expertise of Siemens CNC engineers.

This post processor provides 3- and 4-axis support for SINUMERIK 808D CNCs from Siemens.

Some features include:

- CYCLE 832 Support for High Speed Settings.
- Work offset support matching control capabilities.
- 808D optimized Drilling Cycles (CYCLE 82, 83, 84, 85, 86, 840), with full 4-axis support.
- Numerical tool call with offset D#.
- TOFFR functionality to support cutter compensation wear strategy.
- Optimized Multiaxis toolpath using the FGROU and FGREF commands.
- A Siemens application guide.



# JU60

## 5 Axis VMC

### Highlights:

- 5 Axis Simultaneous
- Built in Spindle (15000rpm)
- Ideal Axis layout with two spindle axis and three table axis
- Symmetrical structure for thermal stability
- Linear scale
- Automatic tool changer (40 Tools)
- Larger Clamping Area (Dia 500mm)
- BBT 40 Spindle taper for higher accuracy
- Higher Rapid traverse rate (X,Y & Z - 48 m/min)
- Pre loaded axial & radial roller bearing to withstand the load exerted during machining
- Trunnion type both end supported A axis table
- Siemens 840D control system

Visit Us @

Hall No. 05

Stall No. B106



AEROSPACE DEFENCE  
AUTOMOBILE OIL & GAS  
MEDICAL AGRI & EARTH MOVERS  
PUMPS & VALVE DIE & MOULD  
GENERAL ENGINEERING

INDIA'S FINEST  
RANGE OF CNC MACHINES  
[www.lmwcnc.com](http://www.lmwcnc.com)

  
INTEGRATED SOLUTIONS





**PARTS CLEANING**

## Aqueous Cleaning Solutions

**H**AKUPUR® cleaners harness the power of multi-functional power surfactants (combination of non-ionic and cationic surfactants) to deterge versatile organic and inorganic soils. Special dual effect action enables HAKUPUR® cleaners to combine the power of emulsification (carrying off the soil/dirt from the components) and demulsification (separating out soil/dirt from a cleaner to its surface for skimming) even at lower temperatures compared to conventional cleaners. HAKUPUR® Cleaners reduce the surface tension by adsorption at the liquid-gas interface. This dynamics induces superb cleaning effect without compromising on the critical factors for industrial applications such as foaming where bubbles or drops are rapidly generated and need to be stabilized.

### A bevy of benefits

With features such as power surfactants, advanced surfactant technology, special additives, and dual-effect action, HAKUPUR® cleaners provide the following advantages:

- Superb cleaning effect
- No foaming even at high pressures
- Better surface preparation for rust protection
- Longer bath life.

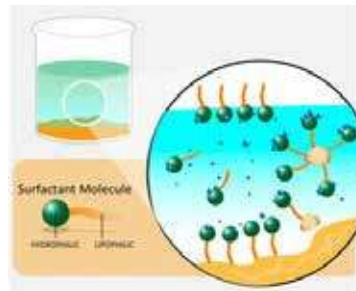

**Zavenir Daubert India Pvt Ltd**  
www.zavenir.com  
Hall 3A, Booth B125

Source: Zavenir Daubert India Pvt Ltd

**NEWS**

## BFW partners with Universal Robots

**Bharat Fritz Werner Ltd**  
www.bfwindia.com  
Hall 1A, Booth A102

**B**harat Fritz Werner Ltd (BFW), a leading machine tool manufacturer in India, in association with Universal Robots, pioneer and leader in Collaborative Robots (Cobots), have joined forces to cater to the MSME segment with new and affordable automation solutions. The aim is to redefine the production processes by deploying



Source: Magic Wand Media

robotic arms through modular, flexible and user-friendly integration solution platform – Arjun.

Ravi Raghavan, Managing Director, BFW, said, “Our strategic partnership will bring collaborative robot technology on a modular flexible platform to MSME shop floors to enhance their manufacturing competitiveness significantly.”

Pradeep David, General Manager, Universal Robots, South Asia, said, “We’re pleased to be working closely with BFW as its CNC machines and Automation Services are well respected throughout the country. Cobots will make it in top 50 disruptive technologies of 2018 in job shops in India.”

**Fibro India Precision Products Pvt Ltd**  
www.fibro.com  
Hall 4, Booth B146

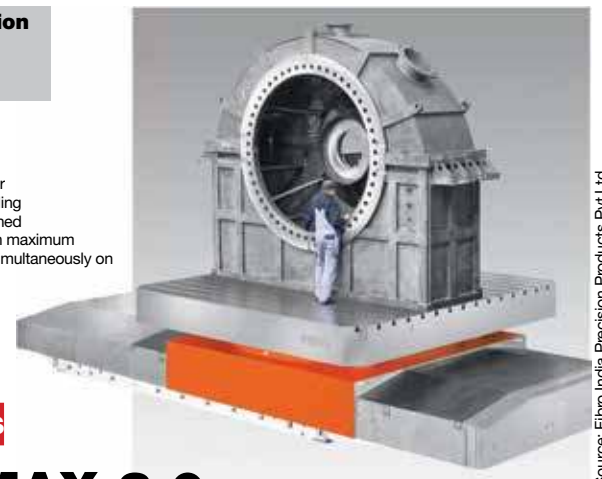

Large individual workpieces or several clamping fixtures holding heavy weights can be positioned accurately and machined with maximum precision in 3-, 4- or 5-axes simultaneously on FIBROMAX tables.

Source: Fibro India Precision Products Pvt Ltd

**ROTARY TABLES**

## FIBROMAX 2.0

Second-generation, heavy-load positioning tables feature high rigidity and efficiency.

**S**pecialist and rotary table pioneer FIBRO presents the FIBROMAX 2.0 series: a completely revised series of its XXL rotary displacement series. In comparison to the first-generation, the bearing diameter and thus the rigidity of the heavy-load positioner has increased significantly – and with virtually unchanged costs. The continuously increasing requirements for the construction of wind power plants, roller bearings, turbines, gearbox cases, and construction machines were the reasons for the new heavy-load concept.

up to 400 tonne are now standard at FIBRO. The heavy-duty tables provide a positioning accuracy of ± 2 angle seconds. The axial run-out and radial concentricity are in a range of a few hundredths of a millimetre. In addition, with the FIBROMAX 2.0 series, a very large dimensioned and highly precise roller bearing provides for maximum rigidity and thus the highest precision during processing. When in a positioned state, a hydraulic table top clamp increases the tangential torque and relieves the gear. The preloaded bearing and a play-free twin-drive also offer optimum conditions for circular milling and simultaneous machining. FIBROMAX 2.0 provides a maximum of process stability at minimum maintenance effort.

### Maximum process stability

Rotary tables for workpiece sizes of 4 x 4 m and transport loads of

**Would you like to be crowned a productivity Champion?**

..... Share your success stories on  
**PRODUCTIVITY | TECHNOLOGY | INNOVATION....**

Win Cash Awards upto  
**₹ 10,00,000**



**IMTMA - ACE MICROMATIC Productivity Championship Awards 2019**

*“Showcasing Competitiveness in Manufacturing”*

No Entry Fee | Multiple Entries Welcome !

Special stream for Micro & Small Enterprises

**Productivity Champions will be crowned at National Productivity Summit 2019 20 - 21 August 2019, Bangalore**

Rush your entries by 15 March 2019

For more details, contact :  
Mr. Abhishek on 080- 66246829 / 6805  
Mobile : +91 9886611007  
Email : abhishek@imtma.in

**imtma**  
Indian Machine Tool  
Manufacturers' Association  
www.imtma.in

Awards Sponsor  
**AceMicromatic**  
Group



# PROGRAM SMARTER... MACHINE FASTER

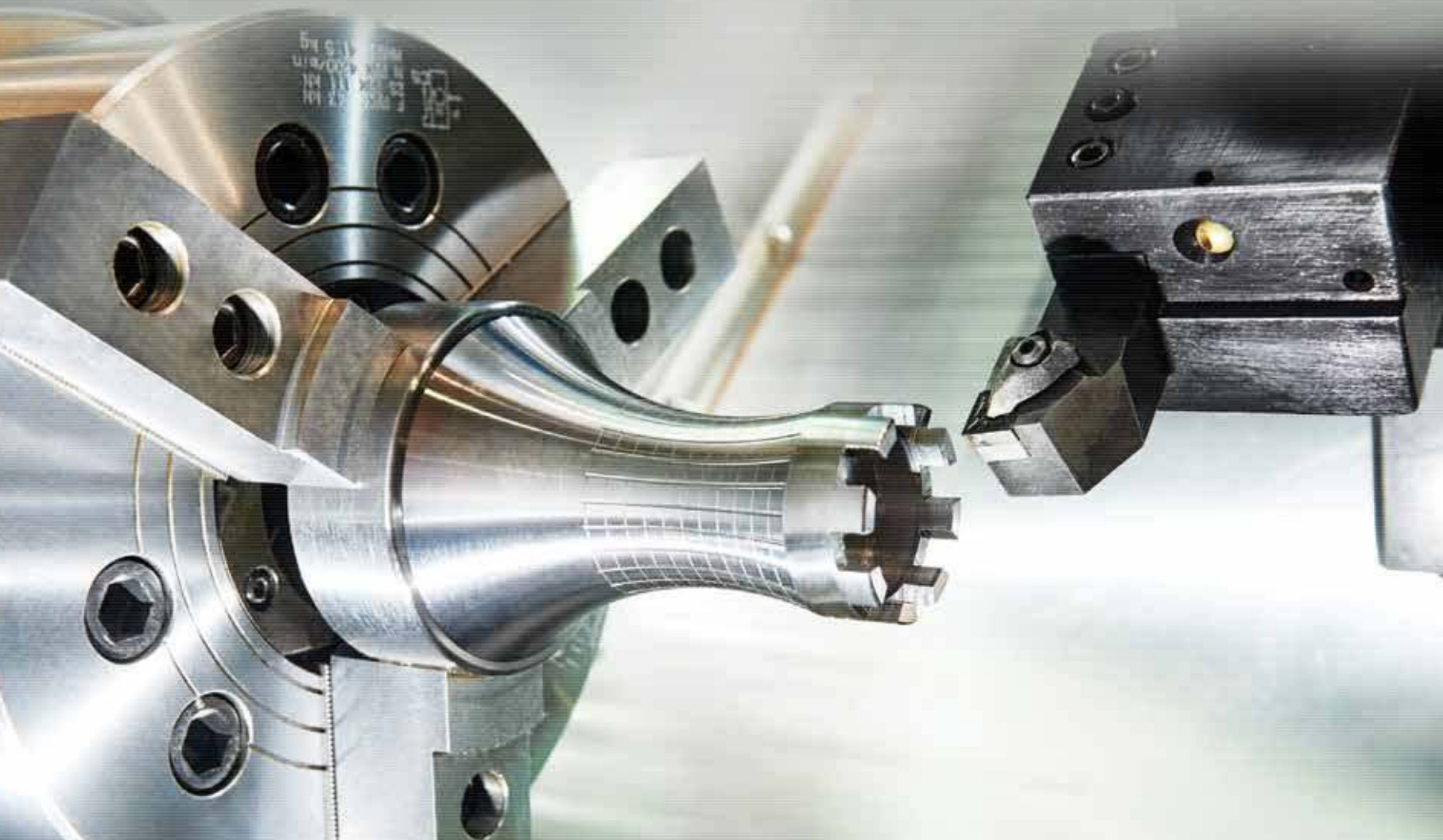

**CAMWorks is Powering SOLIDWORKS CAM**  
First and Best Integrated CAM Software in **SOLIDWORKS**

**CAMWorks Additive Manufacturing**  
First Intelligent Additive & Subtractive  
Manufacturing Solution Available for **SOLIDWORKS**

**Tolerance Based Machining**  
Automatically Creates Toolpaths to Meet Tolerances & Surface  
Finish Requirements – compliant to **Industry 4.0**

VISIT US AT



**BOOTH A 114,  
HALL 6**



**WORKHOLDING SOLUTIONS**

# Zero-Point Clamping System

With technological superiority, the zero-point systems from AMF have virtually revolutionized the zero-point clamping technology market.

**A**MF has introduced highly precise clamping modules with high draw-in, locking and holding forces that ensure perfect clamping in the widest range of applications. The systems are used for set-up time reduction in metal cutting as well as non-metal cutting areas. They also find applications in food, pharmaceutical and chemical industries. The new indexing function of the clamping module prevents the pallet or work piece from twisting especially when a single module is used. Repeatability is within 0.005 mm and accurate positioning at every 90 degree. The module is opened pneumatically with 5 bar and gets mechanically self-locked. The clamping module connection can be disconnected once clamping is achieved. Positioning and clamping gets done in one operation. Pneumatic blow out of chips is a standard option. Opening, closing and support functions can be controlled and interfaced with machine control for safe operations. Modules with various capacities are available.



**Andreas Maier**  
 Workholding  
 Technology Pvt Ltd  
 www.amf.de  
 Hall 2B, Booth B112

Source: Andreas Maier Workholding Technology Pvt Ltd



### “Great Source of Knowledge”

“IMTEX is truly a one of its kind exhibition. I am a regular participant in the show and have seen it growing from edition to edition. It's an excellent platform to learn about the technological advancements from all over the world.”

**MILIND KULKARNI**  
 Managing Director  
 Kulkarni Transpower Pvt Ltd



### “New Technologies All Under One Roof”

“IMTEX 2019 has added several new technologies to its already comprehensive list of display offerings. Tools for safely handling composites is what caught my attention today. It is an emerging field, which is bound to grow.”

**GIRISH RISHI**  
 Manager, Machine Shop  
 United Metallurgicals Pvt Ltd

Nurture Design Skills with Unlimited Learnings @



## DESIGN INSTITUTE

Machine Tool Design Powered by Technovation

& be industry ready Design Engineer



Course starts from  
**04 March 2019**

Presenting IMTMA Certified  
**ELECTRICAL & ELECTRONICS FOR MACHINERIES**  
 at Bangalore

COURSE CONTENT:	COURSE BENEFITS:
<ul style="list-style-type: none"> <li>▶ Fundamentals of Machine Design</li> <li>▶ Fundamentals of CNC Systems</li> <li>▶ PLC for Machine Application &amp; Programming</li> <li>▶ Motors &amp; Drives Selections for machines</li> <li>▶ Electrical Switchgears selection for machines</li> <li>▶ Fundamentals for Electrical Circuit design</li> <li>▶ Training on Electrical Design Tool ePLAN</li> <li>▶ Design of Electrical Control Panels</li> <li>▶ Virtual Projects for Design</li> </ul>	<ul style="list-style-type: none"> <li>▶ Comprehensive Machine Design on Controls &amp; Machine Automation</li> <li>▶ Hands on experience on Electrical System Design, Design of Control Architecture.</li> <li>▶ Hands on experience on Electrical Design Tool ePLAN</li> <li>▶ Confident Design Engineer</li> <li>▶ Placement Support</li> </ul>

For Course Registration: **Rathan, Executive**  
 9743180085, rathan@imtma.in

For Technical query - Mech.: **B.L. Patil, SEO**  
 9916206482, blpatil@imtma.in

For Technical query - Elec.: **L. Gopi, SEO**  
 9986502659, gopi@imtma.in

www.imtmatrainig.in



### “Useful for College Students”

“I am a student and have come here to get acquainted with the new technologies that are being deployed in the modern machine tools. The real-world scenario is always much more advanced than what is taught in colleges. I got to see some interesting applications of automatic control and robotics here at the show.”

**VISHNU DAS**  
 CMAS Technologies  
 Calicut



### “Good Focus on Technologies for Composites”

“My purpose of visit is to search for new machinery with the latest technologies. Although most technologies being exhibited here are already in our workshop, there are some which are new and highly advanced. We need this knowledge to begin with since we are moving from metals to composites.”

**B P GUPTA**  
 Jr. Works Manager  
 Small Arms Factory  
 Ministry of Defence  
 Government of India

# SEE OUR INNOVATION

# AT WORK

Our new range of unique machines give you what you expect from innovation-RESULTS!



**UNITURN 400 HD-TM**



**VERSA TURN**



**FLEXTURN Neo-TWIN WITH GANTRY**



Please visit us at  
**IMTEX-2019, Hall No. 2A - Stall No. A 104**  
from **24th - 30th Jan 2019**, Bangalore

## GEDEE WEILER

A CUT ABOVE THE REST

INDIA'S No.1 EXPORTER  
of lathes to **GERMANY**

GEDEE WEILER PRIVATE LIMITED, Vellore Road, Podanur P.O. Coimbatore - 641 023, Tamil Nadu, INDIA.  
EPABX: +91-422 2413908, 804 and 048 E-mail: sales@gdweiler.com Website: www.gdweiler.com



Legacy continues...





# Spain

## IMTEX INDIA 2019

January 24 – 30

Bangalore International  
Exhibition Centre

HALL 1B  
**Stand D101**



ekin.es  
B106



etxe-tar.com  
C106



FAGOR AUTOMATION

fagorautomation.com  
A106



gurutzpe.com  
C104



ibarmia.com  
D105



juaristi.com  
A108



nicolascorrea.com  
C102



iazgroup.net  
D103



gamor.es  
B105



zayer.com  
B107

### Organizers



**ICEX**



European Regional Development Fund  
A way to make Europe

### In collaboration with



Machine Tool, Accessories, Component  
Parts and Tools Manufacturers'  
Association of Spain



# One Stop Shopping from IPG Photonics, the Market Leader in Fiber Lasers



## PICK YOUR LASER

- Multi-kW
- Pulsed
- QCW
- Sub-kW

## PICK YOUR ROBOT

- ABB
- KUKA
- FANUC
- Other

## PICK YOUR APPLICATION

- Cutting
- Cladding
- Sintering
- Welding
- Cleaning

## PICK YOUR PROCESSING HEAD

- Cutting
- Scanner
- Powder Feed
- Welding
- Wobble Weld

## PICK YOUR WORKSTATION

- Rotary
- Auto Feed
- X,Y
- Multi-axis

ADD TO BASKET

During IMTEX 2019, Please visit us at: **Hall No. 5 Stall No. A128B**



### Our Presence:

- ▶ Bangalore
- ▶ Ahmedabad
- ▶ Delhi/NCR

✉ Sales.india@ipgphotonics.com

☎ +91-95606-08808

🌐 www.ipgphotonics.com



Delhi/NCR: Plot No. 30/32, Knowledge Park - III, Greater Noida, Uttar Pradesh - 201308



## MEASUREMENT SOLUTIONS

That you receive 360° support so that you can rely 100% on accuracy.

This is what **EXACTLY** means to us.



# The New Dimension of Tactile Contour and Surface Measurement

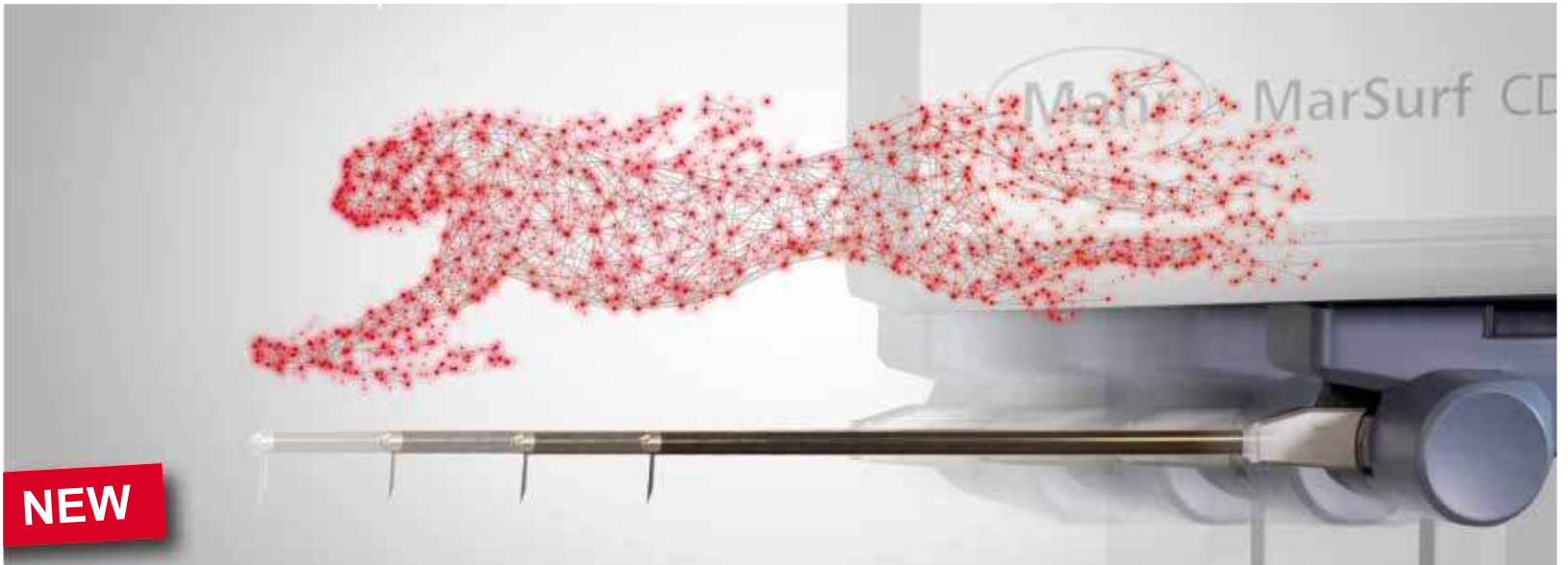

## METROLOGY - MAHR ADVANCES IN MEASUREMENT

Mahr is a world leader in many areas of metrology. Our products stand for accuracy, quality and innovation. Mahr constantly exceeds the limits of what is possible and ensures your lead in metrology. As a partner for the future, we will make your quality assurance more reliable, more automatic, faster, more wireless and even more user-friendly.



At IMTEX 2019, Mahr unveils a new product series for tactile contour and surface measurement. They all have one thing in common: more speed.

Shorter measurement times increase performance - that's what we at Mahr believe. Our new MarSurf devices are therefore optimized to accelerate measurement processes and simplify handling.

Contributing significantly to the shortened measurement times of the new MarSurf devices are:

### 1. Innovative clamping system

For quality assurance, less handling means faster measuring procedures. The key to this is the innovative workpiece clamping system of the new MarSurf devices: it combines a large mounting plate with 50 mm bore dimension and the integrated TY adjustment in such a way that no additional XY table is required. The result: workpieces can be positioned flexibly and quickly.

### 2. Higher axis speeds

The axes of the new MarSurf devices also provide more speed. They move the contour probes along the X-axis about 25 times faster than their predecessors – namely with up to 200 mm/s. Measuring up to 50 mm/s on the Z axis, measurements are now about 5 times faster than other axes on the market. The highly dynamic touch probe also enables measurement speeds of up to 10 mm/s.

### 3. Intelligent probe arm system

With the new MarSurf devices, you can also quickly mount or change a probe. Because: the probe arms are magnetically attached and can be quickly mounted without tools. The probe arms of the MarSurf CD series are also equipped with a data chip, which is automatically read out after mounting. Within seconds, all relevant information about the probe arm used is available.

## Mahr Metrology India Private Limited

Corporate Office: B6, 4th Street, Reddipalayam Road, Mogappair West Estate, Chennai - 600 037. Tel: +91 44 4617 5555

• Ahmedabad • Bangalore • Chennai • Delhi • Hyderabad • Jaipur • Kolkata • Pune

E-mail: [mahrindia@mahr.in](mailto:mahrindia@mahr.in) | For Service: [Service.India@mahr.in](mailto:Service.India@mahr.in) | Website: [www.mahr.in](http://www.mahr.in)







# Asia's Leading Fixture Builder Presents **SmartFix4.0**



For over 45 years Forms & Gears has been supplying Precision Machining Centre Fixtures to the world's leading Auto OEMs and Machine Makers in Japan, Germany, UAE, Qatar, Thailand, Turkey, Indonesia and all over India.

- ☑ IoT enabled Industry 4.0 fixtures for High Performance Machining.
- ☑ Cloud based application that monitors readings from sensors on fixtures.
- ☑ Fixture level analytics to help isolate and troubleshoot faster.
- ☑ Graphical data with robust analysis.



**RV Forms & Gears LLP**  
MF 11, SIDCO Industrial Estate, Guindy,  
Chennai - 600 032, Tamilnadu, India  
Call +91 77570 53326 or email us on  
marketing@rvformsandgears.com  
[www.rvformsandgears.com](http://www.rvformsandgears.com)







LA PRÉCISION EST NOTRE TRADITION

“PRECISION IS OUR TRADITION”

A FEW BIG **AEROSPACE** CUSTOMERS THAT GAVE US

A BIG PRIDE & STILL COUNTING !!

